

Smart Agriculture System

^{#1}Prajakta Nikam, ^{#2}Mansi Sonawane, ^{#3}Rahul Bhingare, ^{#4}Vaishali Kharpude

¹prajakta4798@gmail.com,
²mansionawane98@gmail.com,
³vaishalikharpude@gmail.com,
⁴rahul965713@gmail.com



^{#1234}DEPARTMENT OF COMPUTER ENGINEERING

ICOER, JSPM' S COLLEGE OF ENGINEERING,, WAGHOLI, PUNE

ABSTRACT

These days we are facing the problems like pollutions, grass cut problem, water level in agriculture land etc. In order to overcome these problems, we have thought about the device, which can be performing its functions without causing any of these problems. So we have thought of doing the project on cutting grass, moisture analysis, water supply based on moisture level. This project aims at developing a portable mobile operated agriculture robot as there is manpower reduces. So we have decided to make a battery operated mobile based robot device. The DC motor is connected to blade shaft by the help of belt drive. This will rotate the blade in high speed, cut the grass. This device will help in building of eco-friendly system. Current technology commonly used for cutting the grass is by the manually handled device. In this paper used novel technology. So in this paper we are trying to make a daily purpose robot which is able to cut the grasses in Lawn, water supply based on moisture level in land.

Keyword: Agriculture Robot, Grass Cutter, Moisture Analysis, Water Supply, ESP8266, Ardiuno controller, Battery.

ARTICLE INFO

Article History

Received: 8th December 2019

Received in revised form :

8th December 2019

Accepted: 10th December 2019

Published online :

11th December 2019

I. INTRODUCTION

Farming by the traditional manual methods is in use since the commercialization of agriculture. But with the advent of population growth rate, increasing scarcity of food agriculture should see a boom, instead it has been observed that more and more people are leaving agriculture as an option for earning livelihood. Prominent reasons for this, are envisioned as below:

- Land: The amount of land is inversely proportional to population. And as a result the availability of agricultural land is decreasing. So the need of the era is to increase the yield with lower input on a limited amount of land.
- Urbanization: India is speeding towards globalization, reducing the interest of youth in farming and moreover a difficulty faced by people living in cities to monitor crops on regular basis is a major downfall.
- Disabilities: Disabled people and women found it difficult to manage crops and even people far from

field are unable to monitor their crop on regular basis.

- Ease: Change in human mind set and lifestyle, with more demand of comfort and to reduce man power needed in farming.
- Labour: Lack of availability of labour, leading to reduced care of crops.
- Health Problems: Health problems by manual sprinkling of pesticide and weedicide in the fields.

II. EXISTING SYSTEM

The main problem associated with the field maintenance is that the difficulty in identifying the infected crops increases with the increase in crop field area. Labor cost increases as more manpower is involved when we opt for manual checking. Sometimes the crops may also get damaged due to human intervention. In order to control and prevent these issues we take the help of IOT.

III. LITERATURE SURVEY

1. Design and Implementation of Autonomous Grass cutter Robot Controller

This paper basically focuses on designing an automated grass cutter controller which can use to mow the grass at lawns and playground. It used the concept of sense-act whereby it does not fully depend on the workspace surrounding. The automated grass cutter has the feature of detecting the grass. Besides that it has GPS system which allocated the path for the robot movement. Other than that, some sensor such as sonar sensor which use to detect obstacles, encoder to calculate the distance the grass cutter travel together with the GPS system. [1]

2. Design and Implementation of a Control Algorithm for an autonomous lawn mower

This paper discuss on the way of implementing GPS system for automated grass cutter path flow. Besides that it also stated there they used PID controller to increase the performance of the motor speed which can provide better flow. Besides that, their project also included encoder to calculate distance but their encode was made by magnetic and hall sensor which placed around the wheel and it calculate the number of magnetic field strength while moving which will convert the number of magnet to distance travelled. The grass cutter performance is being watch throughout the whole working process at the base station using wireless transmission. [2]

3. Modified Grass cutter Search Pattern for Areas Comprised of Weighted Regions

This paper discusses on the way the grass cutter move while it work. It used weightage spot or region to determine the correct way of path. With this technique, the grass cutter can find the most important place to cut the grass depending on the amount of weight comprised in order to cover the maximum area and also to minimize the time usage. The region with the most weight will be allocated first followed by the second weight and so on. This is some sort of guided path system whereby it move according to the weight given. With this technique, is able to achieve a good result on area coverage. [3]

4. Design and Modeling a Prototype of a Robotic Lawn Mower

This paper discuss on how to develop a robotic grass cutter with several functions. It objective is to build a grass cutter that do not go out of workspace, do not leave any uncut area, able to avoid collision and the most important that is the robot must be cheap and affordable to everyone. Basically it used PIC microcontroller to perform the grass cutter working process or to run the lawn mower. [4]

5. Survey of Robotic Lawn Mowers

This paper discusses different types of Robotic Lawn Mowers present in the market at present. It discusses different companies and their products and compares them with others.

IV. PROPOSED SYSTEM

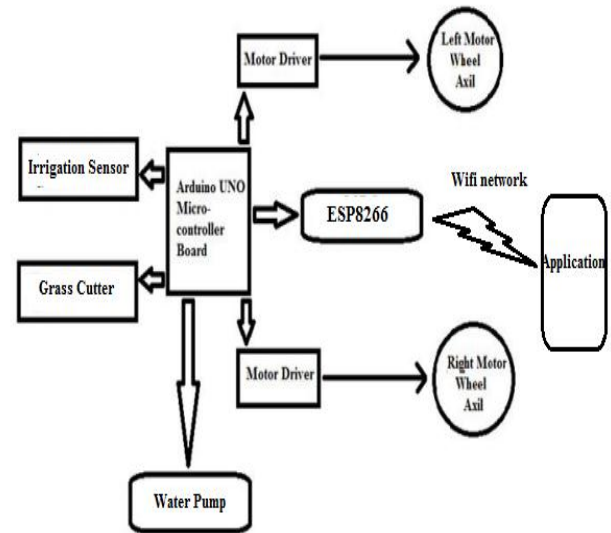

Fig 1. Proposed System diagram

A. Component Used:

Controller:

It is a circuit board of credit card size. It consists of both a microcontroller which is the physical programmable circuit board and a software, or IDE (Integrated Development Environment). It keeps running on PC and is utilized to compose and transfer program code on a PC.



Figure 1: Arduino Uno.

DC Motor

DC motor is a device that converts electrical form into mechanical form of energy. There are many kind of DC motor such as DC motor, separately excited DC motor and self-excited DC motor. DC motor was powered by DC current. There are various voltage input for DC motor and the common voltage input for DC motor are 3V, 5V, 12V, and 24V. There are advantages for DC motor which are the DC motor perform better than AC motor, and DC motor provide excellent of controlling the speed.



Fig 2. DC Motor

ESP8266:

ESP-12E WiFi module is developed by Ai-thinker Team. core processor ESP8266 in smaller sizes of the module encapsulates Tensilica L106 integrates industry-leading ultra low power 32-bit MCU micro, with the 16-bit short mode, Clock speed support 80 MHz, 160 MHz, supports the RTOS, integrated Wi-Fi MAC/BB/RF/PA/LNA, on-board antenna. The module supports standard IEEE802.11 b/g/n agreement, complete TCP/IP protocol stack. Users can use the add modules to an existing device networking, or building a separate network controller. ESP8266 is high integration wireless SOCs, designed for space and power constrained mobile platform designers. It provides unsurpassed ability to embed Wi-Fi capabilities within other systems, or to function as a standalone application, with the lowest cost, and minimal space requirement.

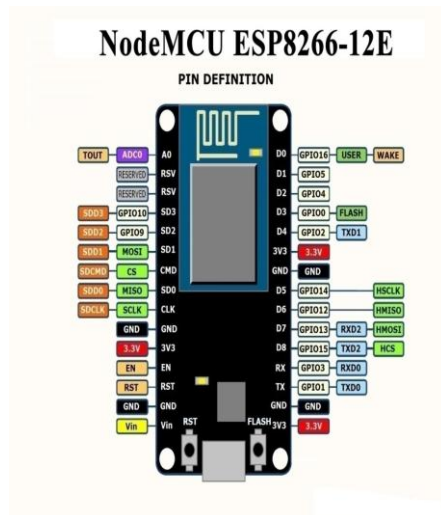

Fig 3. Wi-fi Module ESP8266

Cutter:

This will be used for the primary function of the mower i.e. to cut the grass. Depending on the design, more than one cutter can be used in synchronization as well. Also cutters with different shape or number of blades can be used for the purpose of getting the required cutting speed.

Irrigation sensor:

Irrigation is limited to first few times due to growth of crops. The moisture content of soil is checked by analog sensor. And the water is feed using a PWM controlled water pump till moisture content reaches the level set by user through application.



Fig 4. Moisture sensor

Battery:

It will provide the energy for the working of the robot. The battery of a two wheelers will be able to provide enough power to drive the robot for its working or independent multiple batteries can be used for better performance.

Wheels:

These will be required for the cause of the motion of the body of the robot. The choice of the wheels largely depends on the shape and size of the grass. It will also depend on the required ground clearance of the robot. As treads of the tires can contribute significantly to the performance of the mower, great caution is needed during the decision to choose the particular tires.

B. Algorithm Steps:

Step 1: Start

Step 2: Initialize the system on arduino.

Step 3: The moisture sensor constantly checks moisture and humidity.

Step 4: The soil moisture sensor checks the soil moisture level constantly.

Step 5: The sensor constantly senses humidity of the field and updates.

Step 6: If the water level reduces the permissible level, the relay which is connected to the arduino will turn on the motor.

Step 7: Similarly, if the soil becomes dry, the motor which is connected to the relay will be turned on to wet the field.

Step 8: If the step 7 is completed, it will go to the step 4.

Step 9: Similarly, if the step 6 is over, the command will go to the step 3.

10. Stop.

V. CONCLUSION

An automatic grass cutter with several features has been proposed. Several related works has been studied in order to gain idea on how to build an automatic lawn mower. Most research is on the robot path planning using variety technique. All the technique used are mainly aim for the shortest path, consume less energy.

Advantages:

As an automatic device, this grass cutter has many advantages, some of which are:

- It reduces human effort.
- It has simpler design than most commercial mowers.
- This type of mower is cheaper than commercial mowers.
- It has wider range more than conventional mechanical mowers due to absence of main supply wire.

- It aids elderly users or those with disabilities who are unable to fulfill this task themselves.

REFERENCES

1. M. Wasif (2011). Design and Implementation of Autonomous Lawn-Mower Robot Controller. 2011 7th International Conference. 5-6 September. Emerging Technologies (ICET), 1-5.
2. Smith, J., S. Campbell, and J. Morton. (2005). Design and Implementation of a Control Algorithm for an Autonomous Lawn Mower. Circuits and Systems. 7– 10 August. Midwest Symposium, 456-459.
3. Ousingsawat, J. and M.G. Earl. Modified Lawn-Mower Search Pattern for Areas Comprised of Weighted Regions. American Control Conference. 9-13 July. 918- 923.
4. Mohammad Baloch, T. and K. Timothy Thien Ching. (2008). Design and modelling a prototype of a robotic lawn mower. Information Technology,. International Symposium. 25-28 August. 1-5.
5. Hicks, R.B. and Hall, E. A Survey of Robot Lawn Mowers. SPIE Intelligent Robotics and Computer Vision Conference.